

N6.300 E

Specifications

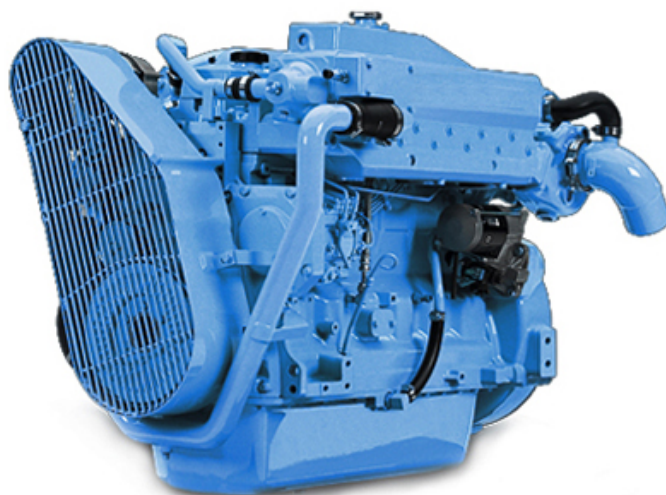

Power at crankshaft	224 kW [305 hp]	Engine base	John Deere
Displacement	6.8 l [414 in ³]	Fuel system	Rotary fuel injection pump Electronically controlled
Configuration	6 cylinders in line	Air intake	Turbocharged Air-to-seawater aftercooler
Operation type	4 stroke Diesel	Cooling	Closed cooling with heat exchanger
Bore & Stroke	106.4 x 127 mm [4.19 x 5 in]	Mounting angle	9° Front up 0° Front down
Compression ratio	17.0:1	Alternator	24 Volt 50 Amp
Rated speed	2600 rpm	Rating	M5
Idle speed	650 rpm	Emission compliance	IMO Marpol Annex VI NRMM (97/68/EC) Tier 2
Peak torque	1005 Nm		
Peak torque speed	2000 rpm		
Dry weight	776 kg [1710 lb]		

N6.300 E

224 kW [305 hp] @ 2600 rpm

TECHNICAL DESCRIPTION

Engine block

- Replaceable wet-type cylinder liners
- Watercooled exhaust manifold

Fuel system

- Fuel filter
- Mechanical fuel injection pump electronically controlled

Lubrication system

- Replaceable full-flow oil filter
- Oil dipstick
- Oil cooler

Cooling system

- Closed cooling with heat exchanger
- Gear driven self-priming raw water pump
- Coolant circulating pump
- Water cooled exhaust elbow

Electrical system & Instrumentation

- 24V 50A alternator
- 24 Volt starter motor
- Complete instrumentation including key switch and alarms
- Extension cable harness with plug-in connection

Air intake

- Turbocharged
- Air-to-seawater aftercooler

Other features

- Flywheel SAE 3
- Flexible engine mounting
- Damper pulley

Optional equipment & accessories

- Keel cooling adaptation
- Dry exhaust elbow
- Complete marine propulsion systems
- Marine transmission adaptation kits
- Throttle and shift controls
- Additional instrumentation, Flying bridge extension harness
- Rigid engine mounting
- Power take off
- Type approval

RATING

- Up to 1000 annual operating hours
- Load factor up to 35%
- Full power for no more than 30 minutes out of each 8 hours of operation. The remaining operation time must be at or below cruising speed

TRANSMISSIONS

Contact your local dealer for more details and availability for transmission model and type.

PERFORMANCE CURVES

Power at crankshaft

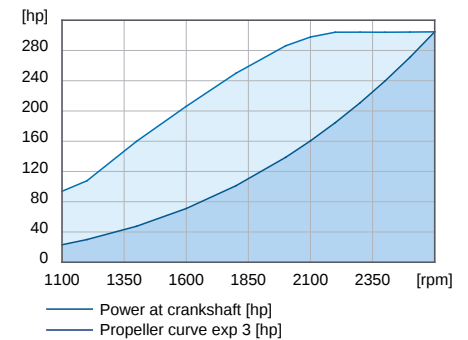

Torque at crankshaft

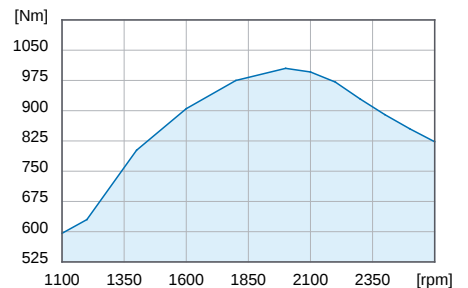

Fuel consumption

At calculated propeller load exp 3

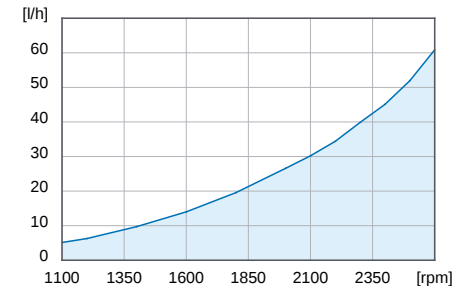

DIMENSIONS BOBTAIL

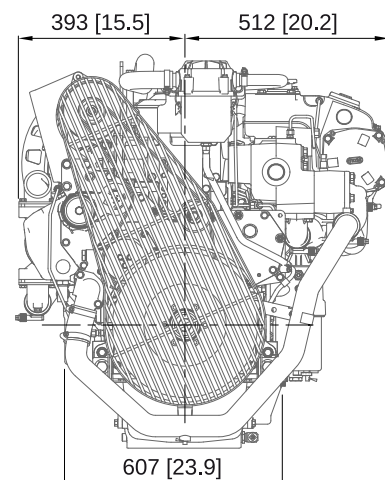
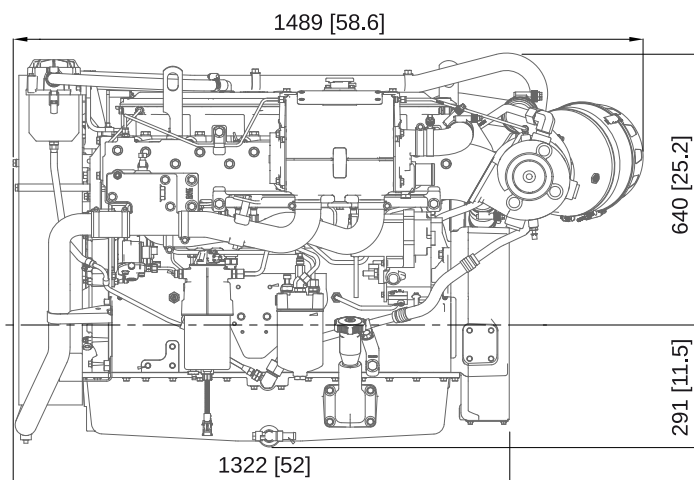

Nanni Industries S.A.S. France

11, Avenue Mariotte - Zone Industrielle
33260 La Teste - France
Tel: +33 (0)5 56 22 30 60
Fax: +33 (0)5 56 22 30 79

Nanni Trading S.R.L

Via Degli Olmetti, 5/B
00060 Formello (RM) - Italia
Tel: +39 (0)6 30 88 42 51/52/53
Fax: +39 (0)6 30 88 42 54

Technical data according to ISO 8665. Specifications are subject to change without notice. Images and illustrations may show non standard equipments. All combination of equipment & accessory are not available.

120914-ENG